

How to...

Replace Upholstered Carriage Bed

Steps 1 & 2

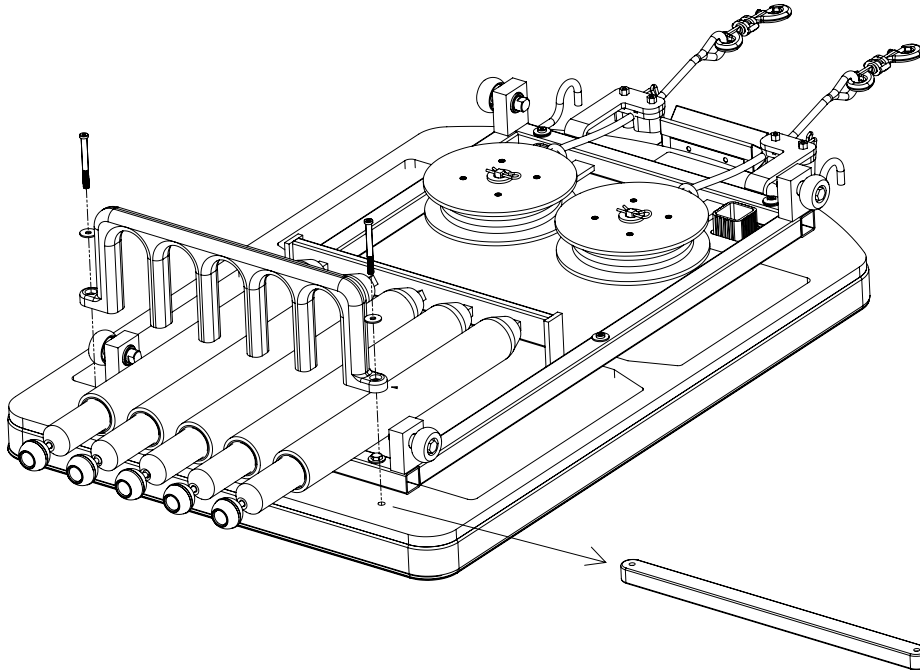

Removal

1. Remove the carriage from your Reformer. Remove the floating rollers and set aside for reuse.
NOTE: Two people are required to remove and reinstall the carriage
2. Unscrew the two bolts and remove the spring holder (including the spacer if your Reformer has one).
NOTE: These instructions also apply to the Rope or Webbing versions of spring holders.

Steps 3 & 4

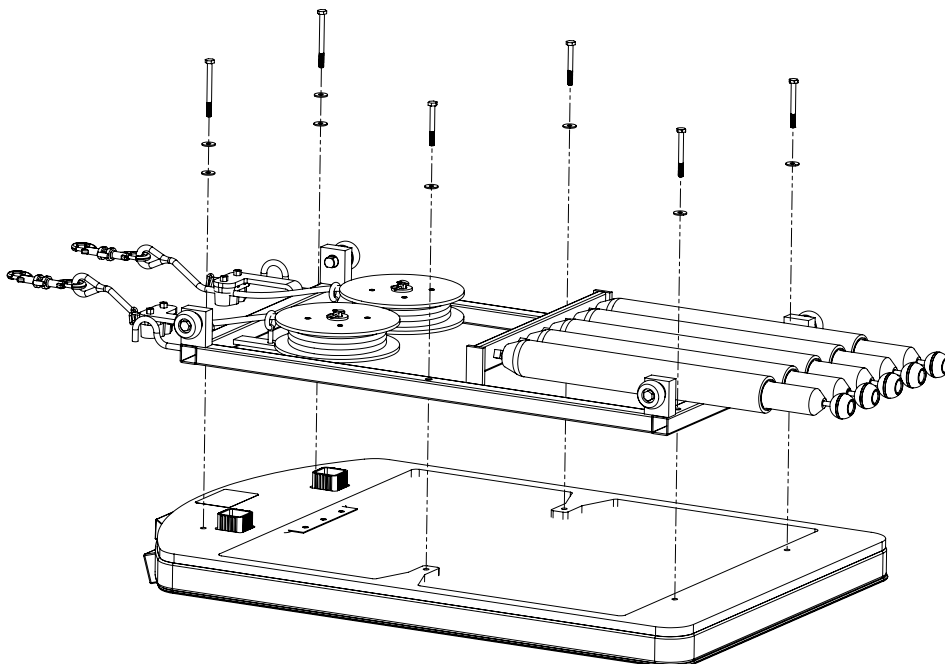

3. Unbolt the six (6) 7/16" hex bolts attaching the frame to the upholstered carriage top from the underside of the carriage.
4. Remove frame from the existing upholstered carriage top and place on top of the new upholstered top.
NOTE: Ensure the new upholstered carriage top has been placed on a smooth surface

Steps 1

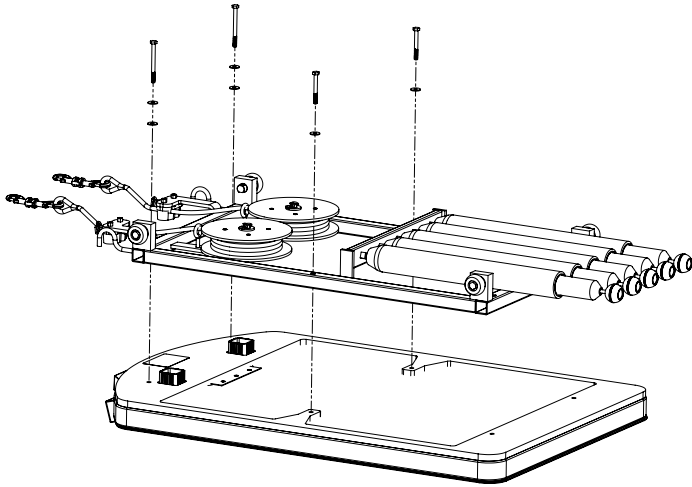

Replacement

1. With the washers on the bolts, replace four (4) of the six (6) 7/16" hex bolts.

NOTE: The remaining two (2) will attach/reattach the Metal Spring Holder.

Steps 2 & 3

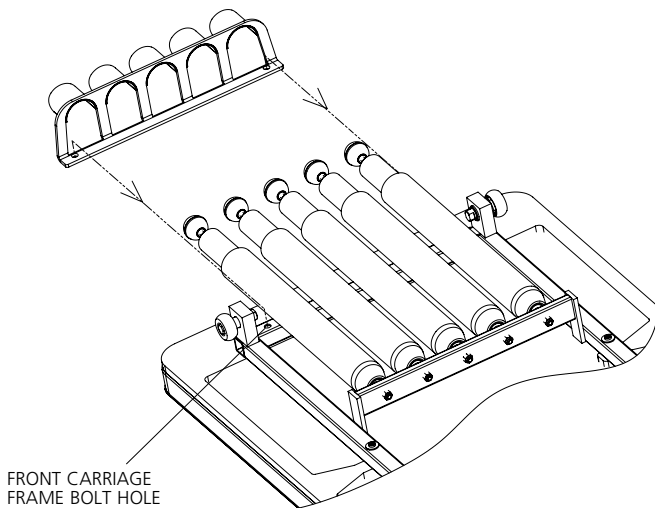

2. Insert springs through the Spring Holder arches, aligning it over the front carriage frame bolt holes.

3. Select the correct bolts from the Spring Holder kit.

NOTE: Use the longer bolts (2-1/2" / 63.5mm) for the professional series of Reformers. If your Reformer is the SPX series choose the shorter bolts (2-1/4" / 57.15mm).

Steps 4 & 5

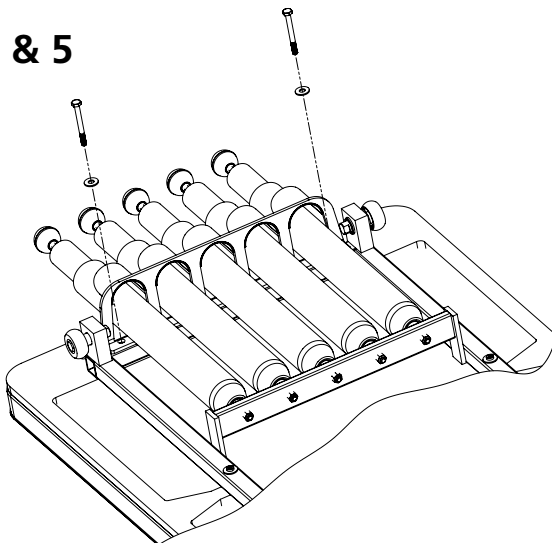

4. Place new washers over the metal spring holder bolt holes. Screw the bolts down through the holder and carriage frame until it is firmly secured using a 7/16" (11.1125 mm) wrench.

NOTE: Confirm all bolts are tightly refastened

5. Clean all rollers including the floating rollers before reinstalling. Replace the carriage into Reformer rails

For more information contact our Customer Service

1.800.910.0001 ext. 288 | 0800.328.5676 ext. 288 (UK) | 416.482.4050 ext. 288 (Customer Care)
customerservice@merrithew.com | merrithew.com