

Spring Holder Upgrade Kit

Retrofit older Reformers with molded spring holders and replacement springs

FOR SPX® & SPX MAX® REFORMERS



Please review this important **installation information** about your new Merrithew™ SPX Reformer Spring Holder Upgrade Kit and keep it handy for future reference.

Spring Holder Upgrade Kit for SPX® & SPX® MAX Reformers

Includes:

- A. Molded Spring Holder + screws (#8 – 1 3/4" QTY-2) and cup washers (#8 QTY-2)
- B. Wooden Carriage Insert + screws (#8 QTY-2)
- C. SPX template
- D. Set of 5 Neoprene Spring Sleeves
- E. Installation instructions

If your Reformer Carriage looks like this, follow instructions A

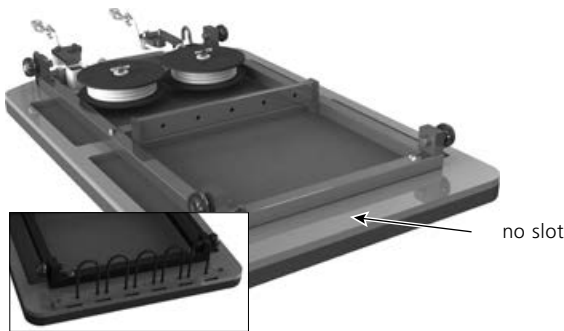

If your Reformer Carriage looks like this, follow instructions B

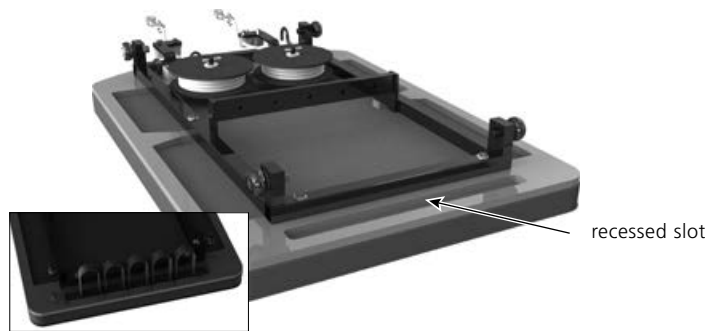

Replacement Instructions "A"

Older Model SPX Reformer with no slot on the underside of the carriage MDF board:

1. As per the Reformer Owner's Manual remove carriage from back of Reformer's rails and turn carriage over (two people are recommended to remove carriage).
2. Detach old springs and rope spring holder from carriage bottom.
3. Place the template (**printed side up**) on the left front corner of the carriage, lining up the curves of the template to the carriage MDF board [FIG. A].
4. Insert a pencil into the center of the printed **X**. Press down and rotate to transfer a mark onto the carriage.
5. Flip the template **over** and line up the right side, marking the other drill hole. [FIG. A]
6. Using a sharp pointed object (i.e. metal punch, awl or nail tip) indent the marks on the left and right side of carriage.
7. Set the molded spring holder onto the carriage bottom with its bolt holes aligned over indented template markings.
8. Place #8 cup washers over spring holder holes (washer cups facing up).
9. Use the two 1/4" x 1 3/4" screws to firmly attach onto the underside of the carriage (do not over tighten screws).
10. Slide spring sleeves onto back end of springs (opposite end from spring balls).
11. Attach springs to anchoring bar, according to the Reformer Owner's Manual.

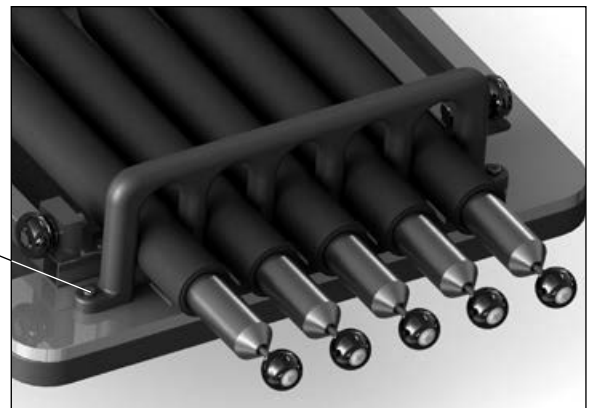
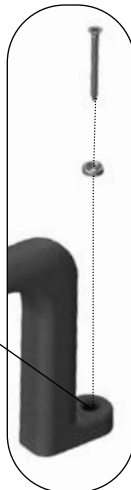
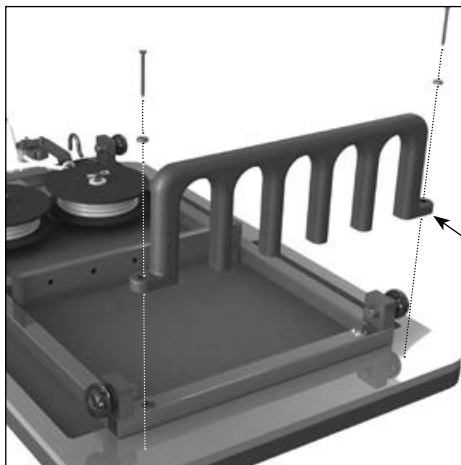

Replacement Instructions "B"

Older Model SPX Reformer with slot on the underside of the carriage MDF board:

1. As per Reformer Owner's Manual, remove carriage from back of Reformer's rails and turn carriage over (two people are recommended to remove carriage).
2. Detach old springs and spring webbing holder from carriage bottom.
3. Place the wooden carriage insert into the slot on the bottom of the carriage and fasten with the two #8 x 1" screws provided (use two middle holes).
4. Align molded spring holder's end holes over wooden carriage insert's outer holes.
5. Place #8 cup washer over molded spring holder holes (washer cups facing up).
6. Use the two #8 x 1-3/4" screws to firmly screw in place the washer cup/spacer and insert (do not over tighten screws).
7. Slide spring sleeves onto back end of springs (opposite end from spring balls).
8. Attach springs to anchoring bar, according to the Reformer Owner's Manual.

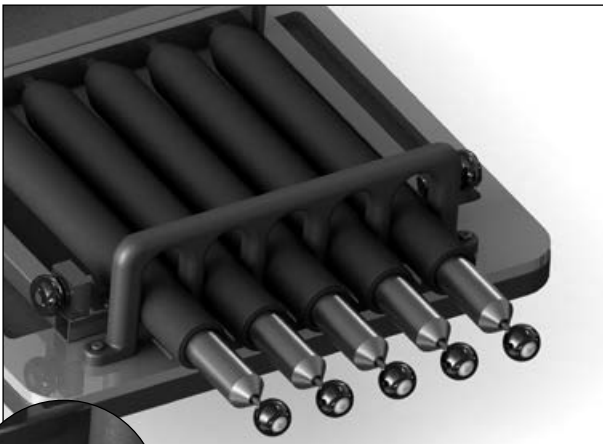
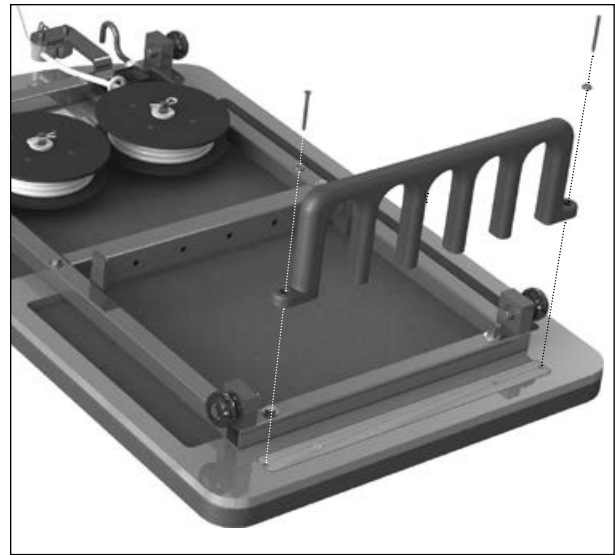
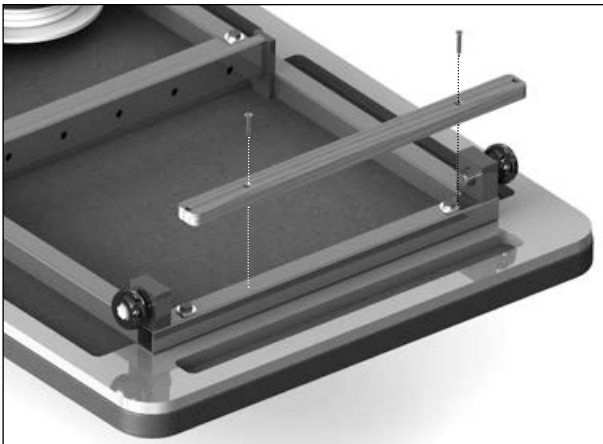

 **IMPORTANT**

Please keep this manual in a safe place.

If you have questions, issues or are missing parts:

Do NOT return this unit to your local retailer,

please contact the manufacturer directly.

customer care@merrithew.com

416.482.4050 | 1.800.910.0001 | 0800.328.5676 UK | ext. 288



2200 Yonge Street, Suite 500, Toronto, Ontario, Canada M4S 2C6
416.482.4050 | 1.800.910.0001 | 0800.328.5676 UK | ext. 288
customer care@merrithew.com | merrithew.com